



Fountain bowl and cover plate shown in standard stainless steel satin finish with "Soft Touch" button valves* bubblers* in mirror finish.

PRODUCT COMPLIANCE*

ADA Compliance
Buy America Act
CA Proposition 65
Components: CA NSF/ANSI 372-2011 (Lead Free)
**More available on request*

*Hands Free" option available

Options and finishes may differ from image shown.

Dimensions in drawing subject to options selected.

Features

- 14" diameter, 16 ga. fountain bowl
- No plastic parts
- 100% made in the USA
- Manufactured with lead-free materials
- Integral drain in bowl for ease of cleaning
- 1/4" steel support arm and wall bracket capable of supporting 500 lbs.
- Cover plate and access panel to match bowl finish or choose from unlimited powder coat colors
- 16 ga. plate secured with tamper-resistant screws for added security
- Standard 6" access panel
- Options include sensor activation, bottle fillers, bottle counters, finishes, bubbler valves, and more...

Recommended Add-ons

Chiller

Equip your fountain with a Filtrine point-of-use or remote chiller to cool your drinking water. We can help you select the most economic chiller model to fit your demand.

Purifier

Ensure that your drinking water is of the highest quality by adding a Filtrine Taste Master® purifier cabinet underneath the fountain or a remote purification system serving all fountains in the building.

Top View

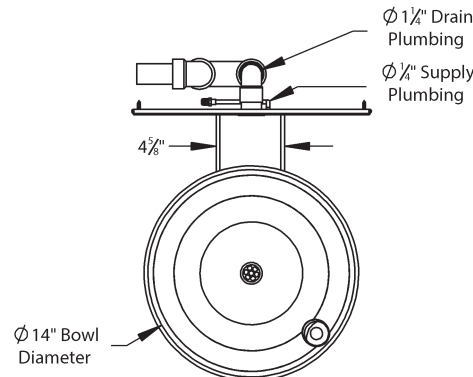

Side View

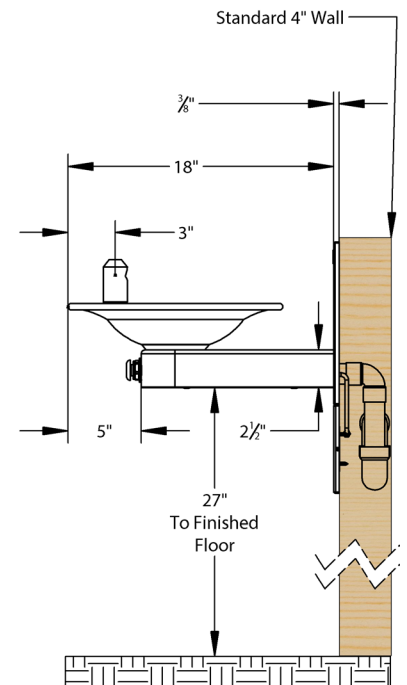

Front View

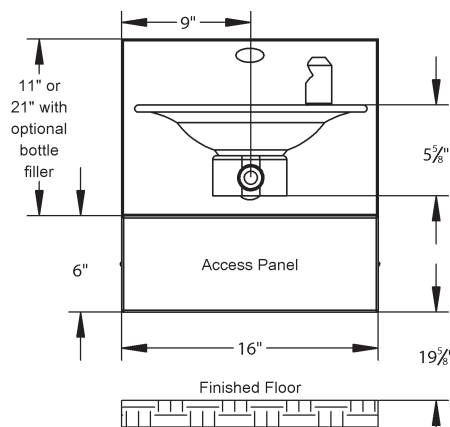

For options, finishes and more see page 2

Standard Security Panel and Vandal Proof Bubbler [S]



"Soft Touch" Button and Projector Bubbler with Recessed Set Screws



16 ga. Plate Secured with Tamper-Resistant Screws for Added Security

Standard Bubbler Controls

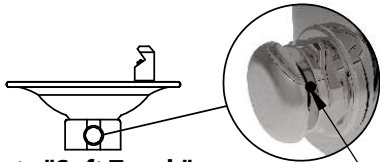

Remote "Soft Touch" Button Valve [S]

Tamper-Resistant Screws in Bubbler and "Soft Touch" Button (if applicable)

"Hands Free" Options



Bottle Counter*
 • Digital display of approximate number of bottles saved through filler usage

*Only available with Hands Free units

Bottle Rest**
 • Located above fountain for reduced splash and one handed operation

**Included with sensor activation



"Hands Free" Sensor Activated F-520 Bottle Filler
 (Choose only one optional filler)

Connect 12v Transformer to A/C Power Supply or
 Use 12v Wall Plug

• Features automatic shutoff (20 sec)
 • Helps prevent vandalism and water waste.

*120/60/1 voltage Required

"Hands Free" Sensor Activated Bubbler

Optional Bottle Fillers: (Choose only one optional filler)

- Mounted 10 1/2" above fountain bowl.
- Requires larger cover plate.
- Comes standard with tamper proof screws.
- Supply plumbing for filler provided by Filtrine.

Soft Touch Button Vandal Proof Filler*



*Hands Free options available.

Soft Touch Button F-520 Bottle Filler*



*Hands Free options available.

Other options are available, please contact the factory for more choices.

Custom Specifications:

Bubbler Options:



F-501



F-501-L



F-502

Available in:
 Stainless Steel,
 Oil Rubbed Bronze,
 or Powder Coat
 options.



F-505

All finish options available.

Fountain Finish (Check One)

Satin Stainless [S] Satin Bronze Statuary Bronze Oil-Rubbed Bronze Oil-Rubbed Bronze Powder Coat Powder Coat _____

Optional Cover Plate Finish (Check One)

Satin Stainless [S] Satin Bronze Statuary Bronze Oil-Rubbed Bronze Oil-Rubbed Bronze Powder Coat Powder Coat _____



Satin Stainless Steel [S]



Satin Bronze



Statuary Bronze

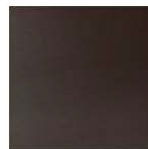

Oil Rubbed Bronze

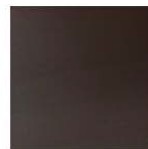

Oil Rubbed Bronze Powder Coat
 (Applied to Stainless Steel)



Powder Coat

Mounting Plate Details (Front)

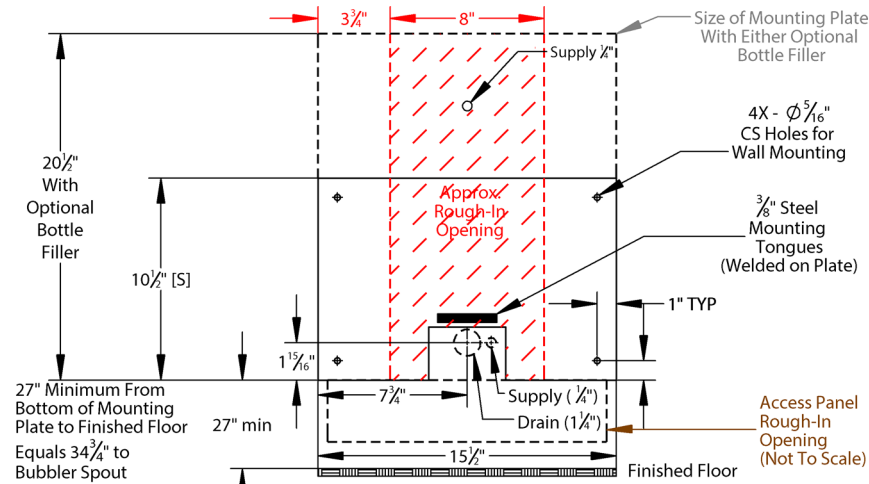

Mounting Plate Rough-In Dimensions (hatched, left)

MODEL	HEIGHT	WIDTH
Standard Plate	10 1/2"	8"
Bottle Filler Station	20 1/2"	8"

Access Panel Rough-In Dimensions (outlined, left)

Model	Height	Width
Standard Plate	5 1/2"	14 1/2"

All views shown are from typical installation of 107-14. Views, dimensions and diagrams may change for specific installation requirements.

Exploded On-Wall Installation View 107-14 with Access Panel

4x - 5/16" CS Lag Bolts (By Others), for Securing Mounting Plate to Mounting Surface (Bracing May Be Needed for Support)

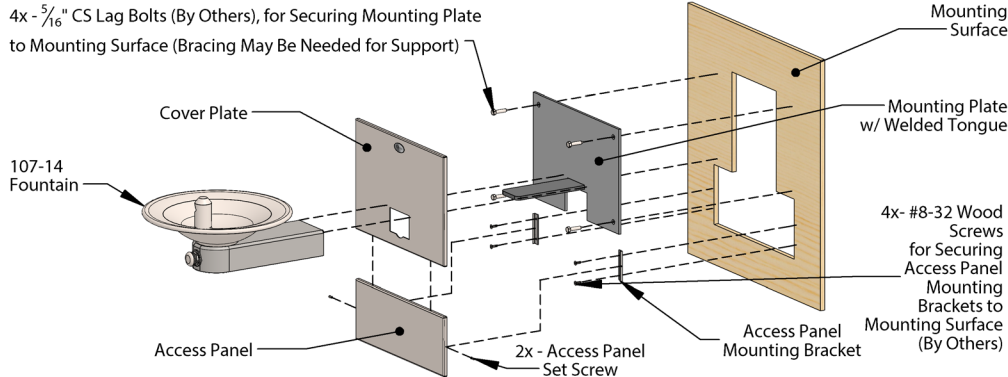

Typical Assembly Instructions (Always Install Per Local Code)

- Cut rough opening as shown above and install blocking or fixture carrier as required to support the assembly.
- If optional access panel was ordered cut a separate rough opening (table, top right) extending below the fountain mounting plate.
- Run drain pipe to center of openings on mounting plate and install drain trap in wall per local code.
- Run supply water with service valve, if necessary.
- If optional bottle filler is included with order, attach piping assembly provided by Filtrine to the back side of the mounting plate with two screws and rubber gasket for standard bottle filler and flare connection for vandal proof bottle filler.
- Fasten mounting plate over rough opening with 5/16" countersunk lag bolts with bottom of plate 27" above the floor to meet ADA fountain height requirement of 34 3/4" to the bubbler spout.
- Install cover plate over the mounting plate for on-wall installations.
- Slide each fountain and vandal proof bottle filler arm (if ordered) over the horizontal tongues protruding from the mounting plate and fasten arms with set screws pushing slightly against the cover plate or finished wall.
- Connect drain line to slip coupling and connect water connection.
- If your model includes the access panel, measure, mark and install the included "L" brackets with #8-32 screws and align panel to cover plate with alignment pins.

On-wall (Mounting Detail With Cover Plate

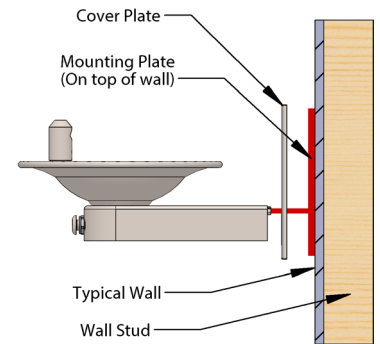

In-wall Mounting Detail Without Cover Plate

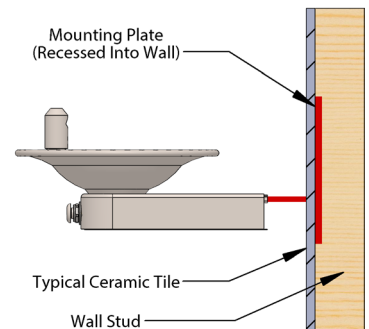

Access Panel Mounting Brackets Installation Details

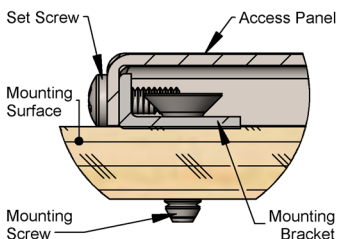

Typical Drain Plumbing Detail

(In-Wall Plumbing Provided By Others, Install Per Local Code)

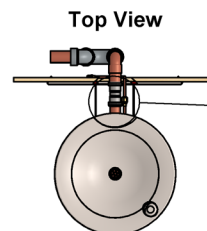
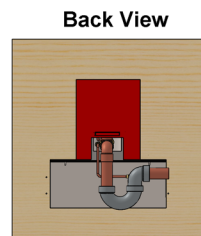

1 1/4" Slip Coupling for Connection of Drain Plumbing (Provided)

1/2" Male Adapter for Supply Plumbing (Provided)