

107-14-HHL

Non-Recessed High/High/Low Drinking Fountain

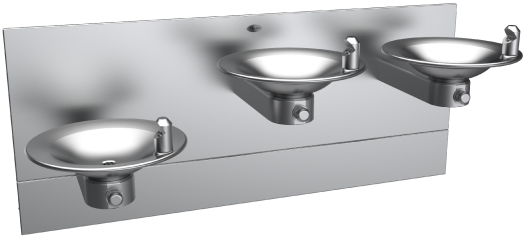

Fountain Finish

(Select One)

- Satin Stainless [S]
- Mirrored Stainless **Flat Surface Only*
- Satin Bronze
- Mirrored Bronze **Flat Surface Only*
- Statuary Bronze
- Oil-Rubbed Bronze
- Powder Coat

Fountain Control Options

(Select One)

- "Hands Free" Sensor Activated Bubbler
F-503 Bubbler Required
- "Soft Touch" Button Activated Bubbler
F-505 Bubbler Required

Accessories

(Choose only one optional filler)

- "Hands Free" Sensor Activated F-520 Bottle Filler
**Includes Bottle Rest*
- Soft Touch Button F-520 Bottle Filler
- Bottle Counter
**Only available with Hands Free Bottle Filler*

Fountain Model Includes:

- [3]14" diameter, 16 ga. fountain bowls
- No plastic parts
- 100% made in the USA
- Manufactured with lead-free materials
- Standard 6" access panel

- 1/4" steel support arm and wall bracket capable of supporting 500 lbs.
- Cover plate and access panel to match bowl finish or choose from unlimited powder coat colors

- Integral drain in bowl for ease of cleaning

Options and finishes may differ from image shown.

Dimensions in drawing subject to options selected.

Top View

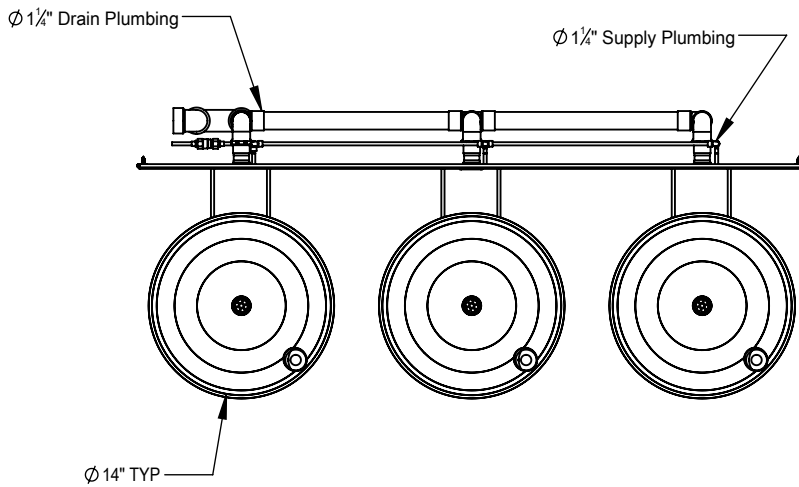

Select Low Fountain Location
 Left [S] Center Right

Side View

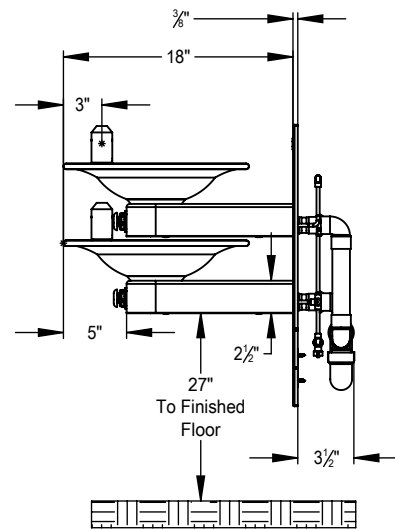

Front View

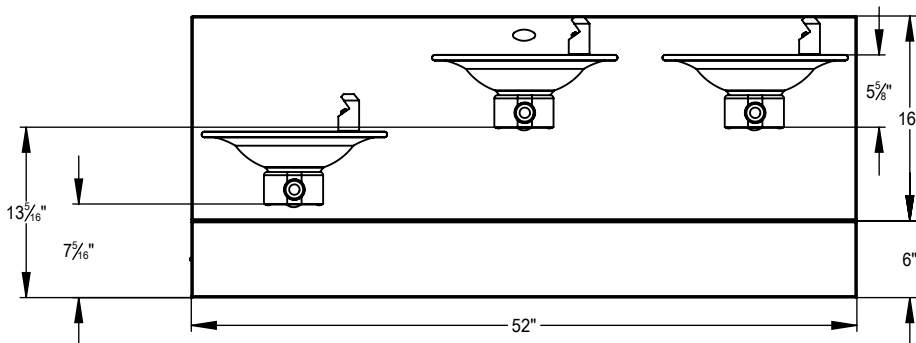

PRODUCT COMPLIANCE*

- ADA Compliance
- Buy America Act
- CA Proposition 65
- Filters: NSF/ANSI Standards 42 and 53 (Lead Free)
- Components: CA NSF/ANSI 372-2011 (Lead Free)
- UL STD 399
- CSA STD C22.2 #120

**More available on request*