

HFBF-RFK

"Hands Free" Bottle Filler Retrofit Kit for Single Fountain



Model HFBF-RFK on 107-16 fountain with optional "Hands Free" label

Features

"Hands Free" bottle filler and cover plate mounts above existing fountain and cover plate.

- Includes sensor, solenoid valve, battery pack, flow-through regulator and circuit board to adjust sensor distance
- [4] lithium AA batteries provided, runs for approximately 400,000 activation cycles
- Automatic shutoff after 30 seconds
- Helps prevent germ transmission and water waste
- Tamper-resistant operation

Labels* (Choose one or both [S]):

-

*Adhere to the fountain cover plate

Finish Options - "Hands Free" Bottle Filler and Cover Plate

Stainless Steel [S]:

- Satin [S] Mirrored
 Powdercoat: _____

Bronze:

- Satin Statuary
 Mirrored Oil-Rubbed

[S] = Standard

Dimensions in drawing subject to options selected.

Mounting Plate

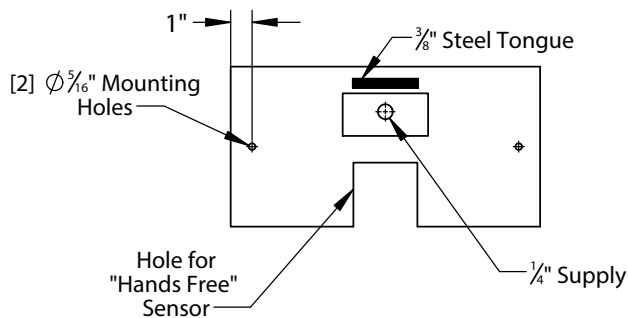

To calculate mounting plate dimensions, subtract 1/2" from cover plate W & H

Existing Fountain Dimensions - Customer Fills Out

W	D _c	H	D _B

Retrofit Access Panel Dimensions - Filtrine Fills Out

W _{RFK}	H _{RFK}	D _{RFK}	L _{BF}

Front View

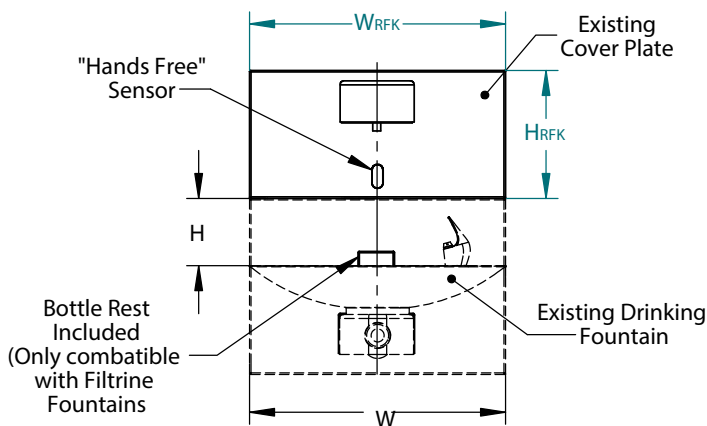

Side View

